

ADDENDUM NO. 3

Date of Issue: **APRIL 9, 2018**

Project: **CONTRACT NO. 18-1
MINERSVILLE AREA SCHOOL DISTRICT
NEW SOFTBALL / TRACK RESTROOMS**

Project Owner: **MINERSVILLE AREA SCHOOL DISTRICT
1 Battlin' Miner Lane, Minersville, PA 17954**

Bid Due Date: **APRIL 12, 2018 AT 10:30 AM** (Local Prevailing Time)
At the Minersville Area School District Office

The following changes, additions, revisions and/or clarifications are hereby incorporated into and shall become part of the contract documents and are issued to amend or clarify the drawings or specifications. Any items not mentioned herein nor affected hereby shall be performed in strict accordance with the original specifications and drawings. Failure of any bidder to acknowledge receipt of this Addendum in the space provided in his Proposal, may be sufficient cause for rejection of his Proposal.

Prior to submission of a bid for this project, all Bidders are urged to visit the Levkolic Associates website at www.levkolicgroup.com to view the most current information pertaining to this project.

I. GENERAL CLARIFICATIONS:

- A. As a clarification, Addendum No. 1 and No. 2 indicate the bid opening time as 10:30 PM. This is incorrect. Bids shall be due on April 12, 2018 at 10:30 AM.

END OF ADDENDUM
LA Project No. 12-026

ADDENDUM NO. 2

Date of Issue: **APRIL 4, 2018**

Project: **CONTRACT NO. 18-1
MINERSVILLE AREA SCHOOL DISTRICT
NEW SOFTBALL / TRACK RESTROOMS**

Project Owner: **MINERSVILLE AREA SCHOOL DISTRICT
1 Battlin' Miner Lane, Minersville, PA 17954**

Bid Due Date: **APRIL 12, 2018 AT 10:30 PM** (Local Prevailing Time)
At the Minersville Area School District Office

The following changes, additions, revisions and/or clarifications are hereby incorporated into and shall become part of the contract documents and are issued to amend or clarify the drawings or specifications. Any items not mentioned herein nor affected hereby shall be performed in strict accordance with the original specifications and drawings. Failure of any bidder to acknowledge receipt of this Addendum in the space provided in his Proposal, may be sufficient cause for rejection of his Proposal.

Prior to submission of a bid for this project, all Bidders are urged to visit the Levkusic Associates website at www.levkusicgroup.com to view the most current information pertaining to this project.

I. GENERAL CLARIFICATIONS:

- A. Drawing Sheet G1 – Door Hardware Schedule – Door hardware Set #02 – Door Deadbolt shall be changed to Schlage B660 series lockset with accessible thumb turn.
- B. Sheet G6 – Building Section – Contractor shall provide bond beam at top of all masonry walls (exterior and interior). All bond beams shall be continuous with (2) #5 continuous bars. Clarification shall also apply to Rear Roof Overhang, 2/G5/G5.
- C. AJ Roofing submitted an RFI asking the following:
 - Q1: Addendum #1 Indicates reroof both dugouts & concession stand. The square footage is given but will need to know if there are any valleys, does the roof slope one way or two, gutters and downspout required, roof penetrations?
 - A1: Existing dugouts are monoslope, shed style roofs with no valleys. New downspouts are indicated on Site Sheet 6 of 13 of the site plans. New gutters shall be added where new downspouts are shown. New Gutters shall be 4" seamless K-type gutters. Existing Concession Stand roof slope 2 ways, approximate midpoint, no valleys. New gutters shall be added where new downspouts are shown. New Gutters shall be 4" seamless K-type gutters. No penetrations existing on dugout and concession stand roofs. Downspouts shall be installed per Roofdrain Connection Detail, Site Sheet 11 of 13. Provide new underground piping, per Site Sheet 7 of 13.
 - Q2: On the new restroom building, gutter & downspout is only shown on one side with the 1'-6" eave overhang. The other eave does not show any. Is the gutter & downspout to be on both eaves? Please clarify.
 - A2: Gutters and downspouts will be provided only on the 1'-6" eave overhang, due to the possibility of vandalism and to keep the gutters away from public circulation paths.

- Q3: Can Karnak #220 Fibered Emulsion Damproofing or Karnak #112 AF Foundation Coating (Both roller applied) be used in lieu of the specified Reinforced-Asphalt Sprayed Damproofing: Two component asphaltic and chopped glass fiber be used?
- A3: Spray applied dampproofing materials shall be provided, as specified.

END OF ADDENDUM
LA Project No. 12-026

ADDENDUM NO. 1

Date of Issue: **MARCH 27, 2018**

Project: **CONTRACT NO. 18-1
MINERSVILLE AREA SCHOOL DISTRICT
NEW SOFTBALL / TRACK RESTROOMS**

Project Owner: **MINERSVILLE AREA SCHOOL DISTRICT
1 Battlin' Miner Lane, Minersville, PA 17954**

Bid Due Date: **APRIL 12, 2018 AT 10:30 PM** (Local Prevailing Time)
At the Minersville Area School District Office

The following changes, additions, revisions and/or clarifications are hereby incorporated into and shall become part of the contract documents and are issued to amend or clarify the drawings or specifications. Any items not mentioned herein nor affected hereby shall be performed in strict accordance with the original specifications and drawings. Failure of any bidder to acknowledge receipt of this Addendum in the space provided in his Proposal, may be sufficient cause for rejection of his Proposal.

Prior to submission of a bid for this project, all Bidders are urged to visit the Levkusic Associates website at www.levkusicgroup.com to view the most current information pertaining to this project.

I. GENERAL CLARIFICATIONS:

- A. Site drawings refer to bid alternates, which were not included on the Bid Proposal Form. Bid Proposal Form within the project manual shall be deleted and replaced with the Bid Proposal form attached (3 Pages).
- B. Drawing Sheet E1 – Electric Fixture E4, Baseboard Heater, as well as all related circuit wiring shall be deleted. However, all five (5) heater circuit breakers shall be provided within the new electric panel and shall be labelled as spare breakers. Contractor shall properly balance all loads.
- C. Any bidders requiring additional site visits to the project site shall contact Mr. Greg Stephen at 570-527-5062 to arrange site visits.
- D. References to the project duration vary within the project documents. The project duration shall be 60 calendar days.
- E. As a clarification, based on information provided, there is an existing electrical line feeding the Soccer Field's Scoreboard that runs from the utility pole adjacent to Soccer Field's Scoreboard along the fence, then down the embankment from the soccer field to the softball field and then turns ninety degrees to meet the existing underground utility box. It is believed the existing electric line is in a plastic conduit and is covered with fine aggregate. The existing line is not encased in concrete.
- F. Refer to attached Guiderail Detail. Guiderail updated to show extra-long posts and 2'-0" Min level area behind guiderail on accordance with PADOT RC-51M. (1 page)
- G. As a clarification, the existing electric panel within the existing concession stand building has a spare 4" conduit leading from the panel to buried electrical box located outside the concession stand. This conduit may be utilized by the Contractor to provide power to the new 100 ampere electric panel in the new restroom building. Contractor shall be responsible to provide new conduit, circuitry, breakers and new concrete encasement for new service to restroom building. Detail for electrical conduit bank is indicated on site drawings 11 of 13.
- H. As a clarification, Plumbing drawings do not show plumbing supply and waste piping sizes. For plumbing supply, point of connection and main piping shall be 3/4" and all branch piping

shall be 1/2", except urinals, which shall be 3/4". For plumbing waste, all main piping shall be 4", toilets shall be 4", sinks and urinals shall be 2" and floor drains shall be 2".

- I. Project Manual, Instructions to Bidders, Section 20 – Additional Documentation shall be deleted in its entirety.
- J. As a clarification, lighting within Utility Room 101 shall be controlled via a manual switch, located adjacent to the room door. Conduit and electrical box may be surface mounted.
- K. As a clarification, Contractor shall be responsible to prepare all necessary permitting documents and submit to the municipality, securing and paying for all permits and inspection fees. Permit and inspection fees will be reimbursed by the Owner upon presentation of receipts from the Township and/or Regulatory Agency. Contractor markup on permit and inspection fees shall not be permitted. The Contractor shall be responsible for any fees incurred due to failed initial inspections.
- L. Bid Add Alternate No. 1 - Concrete shall be 7 bag mix, 4,000 PSI minimum with 4% - 6% air entrainment and shall not contain slag nor fly ash. This clarification shall also apply to Alternate No. 1 – Typical Sidewalk Detail, Site Drawing 12 of 13.
- M. As a clarification, Contractor shall avoid disturbing the existing soccer championship sign. If necessary, sign will be relocated by the School District.
- N. As a clarification, Contractor shall provide full ice and water shield under all new shingles.
- O. Contractor to remove existing shingles on both adjacent dugouts and concession building and replace with shingles that match the proposed restroom building. Work shall include removal of existing shingles, underlayment and drip edge. Remove and replace flashing as necessary. Proposed shingles work shall include installation of new full ice and water shield under all shingles, drip edge, and shingles. Removal of existing material from the site is incidental. Dugout roofing areas: approximately 222 SF each. Concession Stand roofing area: 406 SF. Total Roof Area (in addition to new restroom building) = approximately 850 SF.
- P. Balton Construction submitted an RFI asking the following:
 - Q1: What is to be used for the perforated metal ceiling?
 - A1: Perforated metal ceiling shall be non-corroding (galvanized metal, stainless steel, fiberglass or plastic) and shall be rigid enough not to sag and installed in sections or frames so as to minimize future maintenance access for plumbing and ventilation items. Ceiling shall be attached to bottom chord of new trusses. Utility Room 101 shall not receive perforated metal ceiling. Refer to <http://www.mcnichols.com/gallery/application-photos/ceilings> for examples of such materials. Other options include the provision of acoustical metal decking. Non-corrosive finish shall also apply. Install in maximum lengths to minimize joints.
- Q. Spotts Brothers, Inc. submitted an RFI asking the following:
 - Q1: The finish schedule on G1 lists wall finishes in epoxy paint. Spec 09 91 23 on interior walls call for MPI latex/water based. Which do you want?
 - A1: All block (interior and exterior) shall receive new Sherwin Williams Loxon Block Surfacer. Exterior block surfaces shall receive two coats of Sherwin Williams Loxon XP. Interior block shall receive two coats of Sherwin Williams Pro-Industrial Pre-Catalyzed Epoxy in Semi-Gloss finish.

- Q2: Perforated metal ceilings. To be painted or prefinished? If prefinished will it be a stock/standard?
- A2: Perforated metal ceilings shall be prefinished. Standard white color, to match wall color.
- Q3: Detail 2/G5 calls for T&G 5/8 plywood and H clips. Which one or will that be a builder's choice?
- A3: Contractor shall provide standard edge plywood with H clips.
- Q4: Note 1 under the electric fixture schedule states exhaust fan to be roof mounted and service all four restrooms. Seeing nothing detailing ductwork or ceiling grilles we're assuming you're thinking the perforated metal ceiling would suffice. Our concern is the vented vinyl soffits. Because vented soffit typically allows more air flow than perforated metal ceiling materials it seems likely not much air would be removed from the restroom being used. A metal duct from the fan into the attic space and then duct runs to each restroom with a grille would do a better job of getting the air out.
- A4: It is anticipated the attic vent will be centrally located within the building, near the ridge line. No ductwork is anticipated for ventilation. All exterior soffit material shall be changed from vented to solid soffit material.

END OF ADDENDUM
LA Project No. 12-026

BID PROPOSAL FORM

PROJECT IDENTIFICATION: MINERSVILLE AREA SCHOOL DISTRICT
SOFTBALL/TRACK RESTROOMS
1 BATTLIN MINER DRIVE, MINERSVILLE, PA 17954

CONTRACT IDENTIFICATION: LA Project No. 12-026

BID SUBMITTED TO: MINERSVILLE AREA SCHOOL DISTRICT
1 BATTLIN MINER DRIVE
MINERSVILLE, PA 17954

THIS BID SUBMITTED BY: _____

In compliance with the Advertisement for Bids, BIDDER hereby proposes to perform all Work for the Construction contract in strict accordance with the Contract Documents within the timeframe set forth therein and at the prices stated therein. BIDDER accepts all the terms and conditions of the Invitation to Bid, Instructions to Bidders, and General Conditions, including without limitation those dealing with the disposition of Bid security. This Bid shall remain subject to acceptance for 90 days after the day of bid opening. BIDDER will sign and submit the Agreement with the Bonds, Insurance and other documents required by the bidding requirements within 15 days after the date of Owner's Notice of Award. By submission of this BID, each BIDDER certifies, and in the case of a joint BID, each party thereto certifies as to his own organization that this BID has been arrived at independently, without consultation, communication or agreement as to any matter relating to this BID with any other Bidder or with any competitor.

BIDDER hereby agrees to commence work under this contract on or before a date to be specified in the NOTICE TO PROCEED and to fully complete the project within 60 consecutive calendar days thereafter. BIDDER further agrees to pay as liquidated damages, the sum of \$200.00 for each consecutive calendar day thereafter as provided in the General Conditions.

BIDDER acknowledges receipt of the following ADDENDA (if any): _____

The BIDDER shall submit a Bid Total for all work included in this contract. On this page, the BIDDER shall list the Bid Total. All change orders shall be executed on the document provided in the Contract Documents and subject to the terms set forth in the General Conditions. Owner reserves the right to reject any or all Bids or limit the scope of the work. BIDDER agrees to perform all work described in the Contract Documents for the following:

The unit price for each of the items listed below shall include its prorated share of overhead so that the sum obtained by multiplying the quantity shown for each item by the unit price represents the total amount for each item. Any bid not conforming to this requirement may be rejected as informal.

The Contractor shall familiarize themselves with the site and the Contract Documents and shall be prepared to complete the work items listed. The quantities shown are approximate and are given to assist the Bidder in determining their total bid amount to complete all work.

LUMP SUM BID TOTAL:

Lump Sum Base Bid Total shall include all work associated within the Contract Documents.

_____ Dollars (\$ _____)
(Words) (Figures)

Amounts are to be shown in both words and figures. In case of discrepancy, the amount shown in words will govern.

BID ALTERNATES:

The following Bid Alternate Price(s), supplied by Bidder, shall be a total installed, in-place, fully operational price, including all required material (inclusive of waste), labor, equipment, supervision, general conditions, temporary power, general cleanup, dumpsters, final cleanup, permit fees, overhead, profit, all bonds and applicable taxes, complete and ready for use by the Owner. Should the Owner elect to accept the Bid Alternates, the cost supplied by the Bidder, will be ADDED TO or DEDUCTED FROM the Lump Sum Base Bid supplied by the Bidder, as indicated within the description of the Alternate.

BID ADD ALTERNATE NO. 1:

Bid Add Alternate No. 1 – Contractor shall provide approximately 58 square yards of concrete sidewalk around the proposed restroom building, as indicated on Sheet 5 of 13 of the site plans, in lieu of proposed bituminous paving for the same area, included within the base bid. Concrete sidewalk profile shall be per Sheet 12 of 13 of the site plans.

Concrete shall be 7 bag mix, 4,000 PSI minimum with 4% - 6% air entrainment and shall not contain slag nor fly ash.

Should the Owner accept Bid Add Alternate No. 1, the cost will be ADDED TO the Lump Sum Base Bid.

TOTAL ADD ALTERNATE NO. 1 BID AMOUNT:

_____ Dollars (\$ _____)

BID ADD ALTERNATE NO. 2:

Bid Add Alternate No. 2 – Contractor shall provide 30 square yards of additional paving to connect new paving area to existing bleacher area – Actual location to be designated by the Owner in the field. Paving profile shall match new paving profile.

Should the Owner accept Bid Add Alternate No. 2, the cost will be ADDED TO the Lump Sum Base Bid.

TOTAL ADD ALTERNATE NO. 2 BID AMOUNT:

_____ Dollars (\$ _____)

Respectfully Submitted:

Name of Bidder

Name of Firm or Corporation

Address

Signature

Title

Date

Telephone Number

Fax Number

IRS Employers I.D. Number:

Company DUNS Number

(Seal - If BIDDER is a corporation)

ATTEST: _____

Additional Signatures if required (i.e.: Joint Bid)

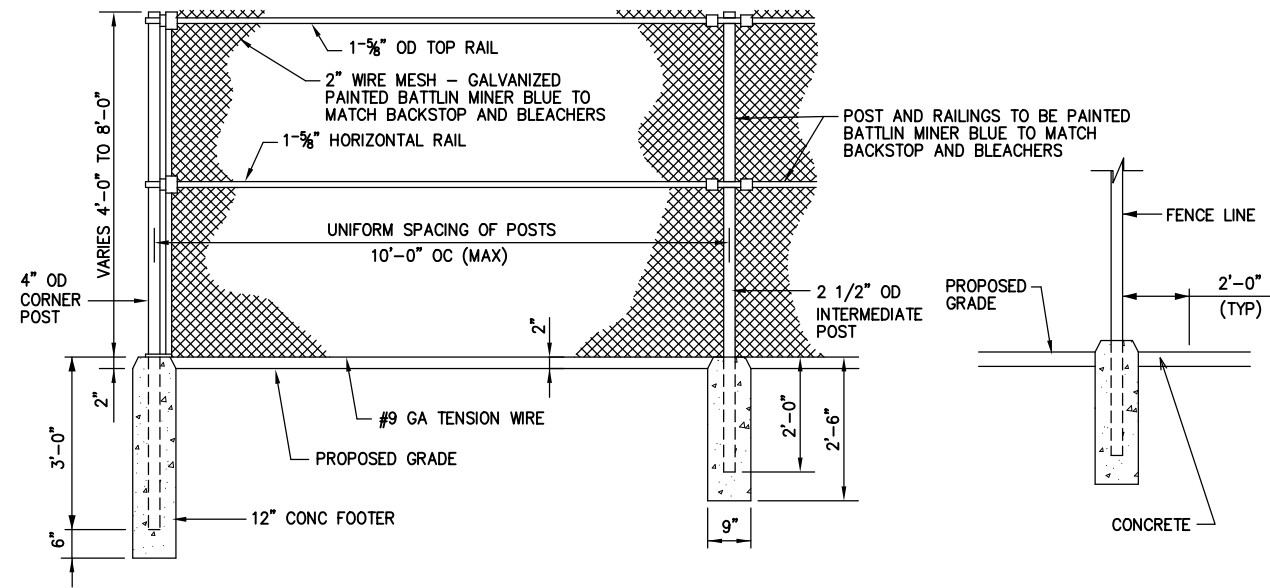

CHAIN LINK FENCE DETAIL
N.T.S.

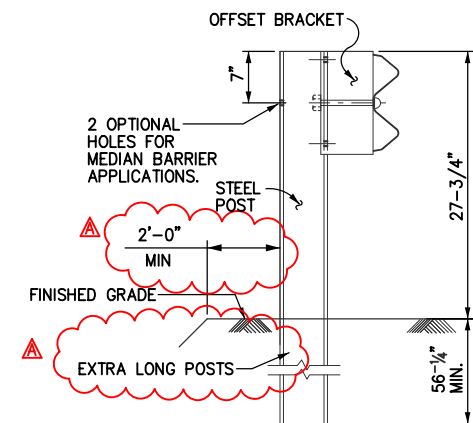

TYPE 2-S GUIDE RAIL DETAIL
N.T.S.



Dial 8-1-1 or 1-800-242-1776 not less than 3 business days nor more than 10 business days prior to the start of excavation

Pennsylvania One Call System Serial Number 20180530596

Rev	Date	By	Chk'd	Description
A	03/26/2018	SJR	CGB	GUIDE RAIL DETAIL UPDATE, EXTRA LONG POST, 2'-0" MIN

Copyright 2018, of Alfred Benesch & Company. All rights reserved. This plan and design content is the property of Alfred Benesch & Company. Use, reuse, reproduction or modification of this plan or design information, or any part thereof, is strictly prohibited, except by written permission of this firm.

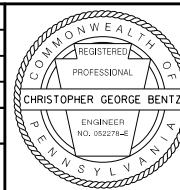

Alfred Benesch & Company
400 One Norwegian Plaza
Pottsville, Pennsylvania 17901
570-622-4055

Minersville Area School District
Softball Field Restrooms

Site Details

Cass Township, Schuylkill County
Pennsylvania